

# Solitary Confinement . . .

By George Swanson

Left click to advance.

# Solitary Confinement . . .



Is it torture?

# Torture

. . . any act by which severe pain or suffering, whether physical or mental, is intentionally inflicted on a person . . . .

– *U.N. Convention Against Torture, Article 1.1*

physical

physical

and

physical

and

mental

# Some Physical Torture





# Some Physical Torture

A SWAT team cuts the orange jump suit off an inmate in handcuffs and leg irons. He keeps screaming as they carry him naked through the Maine supermax.



# Some Physical Torture



# Some Physical Torture

Black helmeted officers strap the inmate in a restraint chair. He continues to scream as one officer holds his head and Maces him in the face.

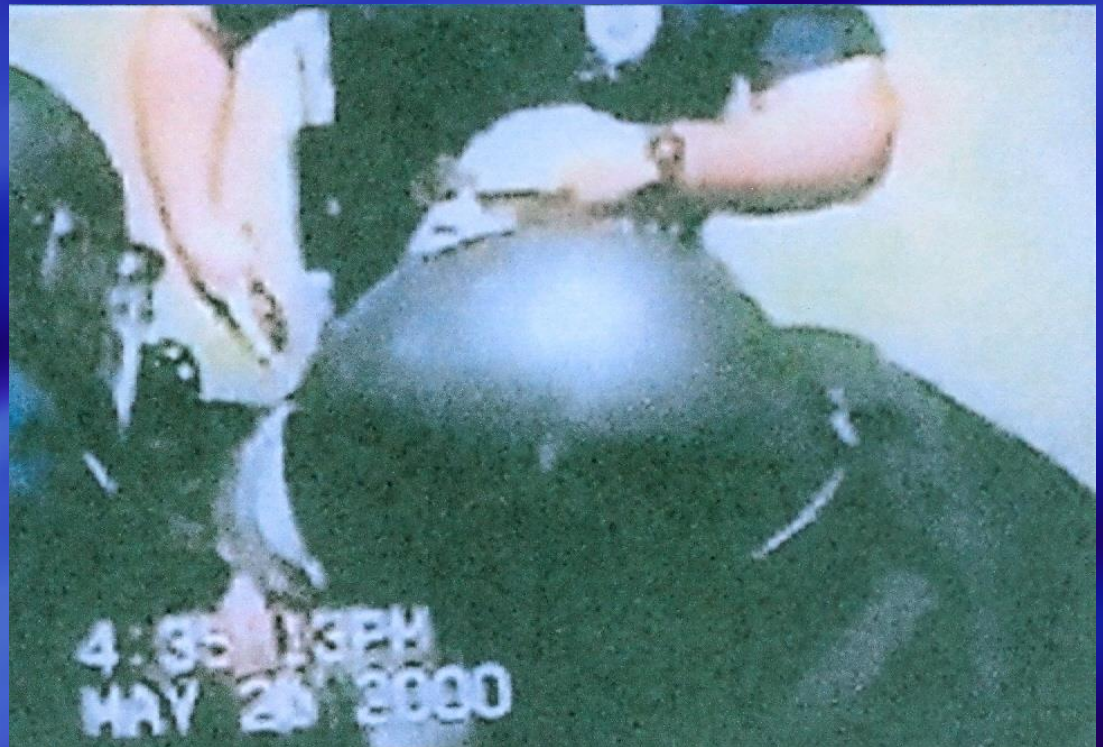

# Some Physical Torture



# Some Physical Torture



**Charles Graner  
cocks his fist  
above Iraqi  
prisoners in  
Abu Ghraib**

# Some Physical Torture



He may have learned torture working in a Pennsylvania supermax.

# Some Physical Torture



We sentenced him to 10 years in Leavenworth for doing what we trained him to do.

# Mostly Mental Torture

Isolation is the worst thing we do to people.

– *Washington State Prison Official*



# Mostly Mental Torture

Solitary confinement left prisoners  
in a semi-fatuous condition.

*– U.S. Supreme Court, 1890*

# Mostly Mental Torture

16 to 19 year olds became like  
Zombies.

*– N.Y. State Supermax Chaplain*

# Mostly Mental Torture

Solitary confinement is  
dehumanizing.

– *Lorna Rhodes, Anthropologist*



Eastern State Prison, Philadelphia, 1822  
Solitary Confinement



Charles Dickens saw it and wrote:

I hold this slow and daily tampering with the mysteries of the brain, to be immeasurably worse than any torture of the body.

And because its ghastly signs and tokens are not so palpable to the eye and sense of touch as scars upon the flesh . . .

. . . because its wounds are not upon the surface, and it extorts few cries that human ears can hear . . .



. . . therefore I the more denounce  
it, as a secret punishment which  
slumbering humanity is not  
roused up to stay.

# Solitary Confinement

## 23 Hours a Day



An inmate looks at the photographer through the slot where he gets his food and where he is handcuffed.



# Solitary Confinement

de Tocqueville visited American prisons in 1833

He wrote:

- We saw the evil effect of solitude.
- This system, fatal to the health of the criminals, was likewise inefficient in producing their reform.

# A Solitary Confinement Cell

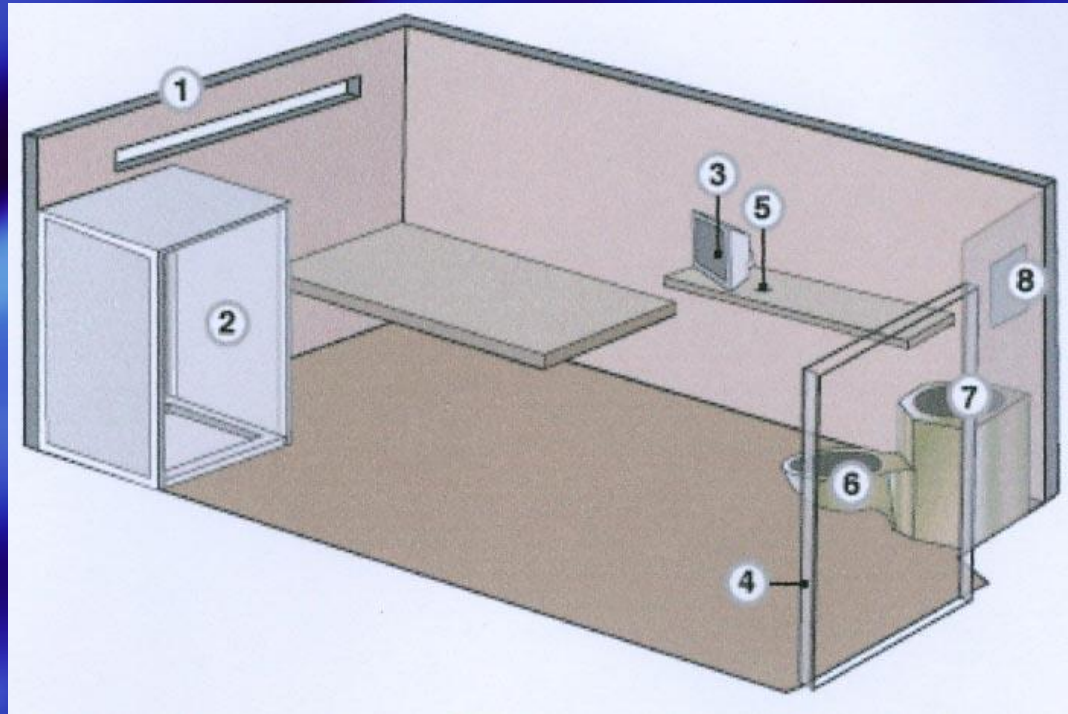

1. 7 feet by 12 feet with small slit window opening on sky and prison wall. No grass or trees in sight.
2. Shower works on timer.
3. Small B/W TV for educational programs, some prisoners only.

# A Solitary Confinement Cell

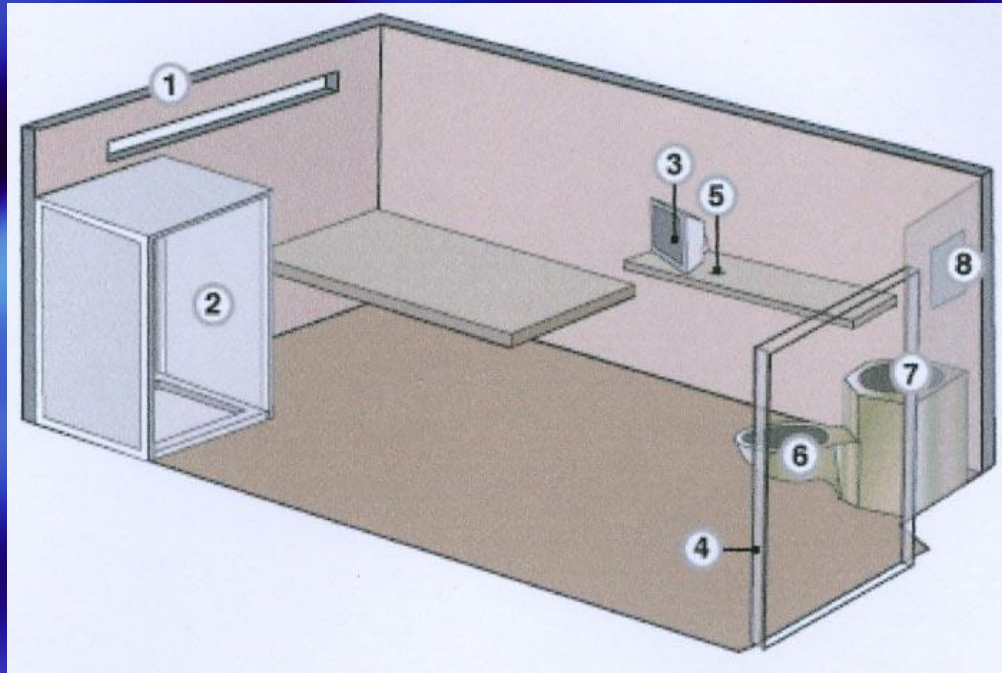

4. Heavy steel door or grate with small slot for handcuffing or food. Slot may be coated with dried blood, feces and urine.
5. Writing desk.
6. Toilet which shuts off if blocked.
7. Sink.
8. Steel mirror, not smashable glass.

# U.S. Supreme Court

1890

- Solitary confinement left prisoners in a semi-fatuous condition.
- The justices saw it as a form of what some people now call no-touch torture.

— *History Professor Alfred W. McCoy*  
*University of Wisconsin at Madison*

# A Typical Cell

In the federal supermax prison in Florence, Colorado



A solitary confinement prison is called a “supermax.”



# California's Pelican Bay Supermax



The X-shaped prison holds 1,300 inmates in solitary.

# California's Pelican Bay Supermax



A naked inmate spreads his toes & buttocks. He is handcuffed through the cuff and food slot before leaving his cell.

# Solitary Confinement

Belongs with

- The rack
- The thumbscrew
- The wheel
- Protracted questioning & cross questioning
- And other ingenious forms of entrapment
  - *U.S. Supreme Court 1940*

Solitary disrupts profoundly  
the sense of the personality.

– *The U.S. Senate 1994*

# The Federal Supermax

400 prisoners in solitary confinement



Internationally honored  
criminologist Hans Toch  
says . . .

A supermax . . .

Impairs the mental health of  
prisoners.

# Hans Toch

World Acclaimed Criminologist Says,

A supermax . . .

Is a gulag.

# Hans Toch

World Acclaimed Criminologist Says,

A supermax . . .

Is reminiscent of traditional  
inquisitory tribunals.



# Hans Toch

World Acclaimed Criminologist Says,

In a supermax . . .

Officers and prisoners are  
situationally dehumanized.

# Hans Toch

World Acclaimed Criminologist Says,

In a supermax . . .

Youthful prisoners regressed into something less than human.

# Father Joseph Romano

NY State supermax chaplain

He saw 16-to-19-year-old inmates.

# Father Joseph Romano

NY State Supermax Chaplain

He says,

The light went out in their eyes.

# Father Joseph Romano

NY State Supermax Chaplain

He says,

They became like zombies.

# Father Joseph Romano

NY State Supermax Chaplain

He says,

I'd talk to them  
through the food slot,  
and all I got back  
was a blank stare.

# Father Joseph Romano

NY State Supermax Chaplain

He says,

I spent a lot of time trying to  
console scared kids  
who cried and cried.

# Father Joseph Romano

NY State Supermax Chaplain

He says,

The supermax is only about punishment and breaking down these guys.



# Solitary Confinement



Maine keeps 100 prisoners in solitary confinement.  
That's more than in the whole country of England

# Lance Tapley

Journalist in Augusta writes about Maine's supermax . . .

It is torture.

# Lance Tapley

Journalist in Augusta writes about Maine's supermax . . .

It is isolation – sometimes for years.

# Lance Tapley

Journalist in Augusta writes about Maine's supermax . . .

23 hours a day in a tiny cell.

# Lance Tapley

Journalist in Augusta writes about Maine's supermax . . .

It is sensory deprivation.

# Lance Tapley

Journalist in Augusta writes about Maine's supermax . . .

Some prisoners howl in constant agony.

# Lance Tapley

Journalist in Augusta writes about Maine's supermax . . .

Inadequate food is shoved through  
an unsanitary slot in the door.

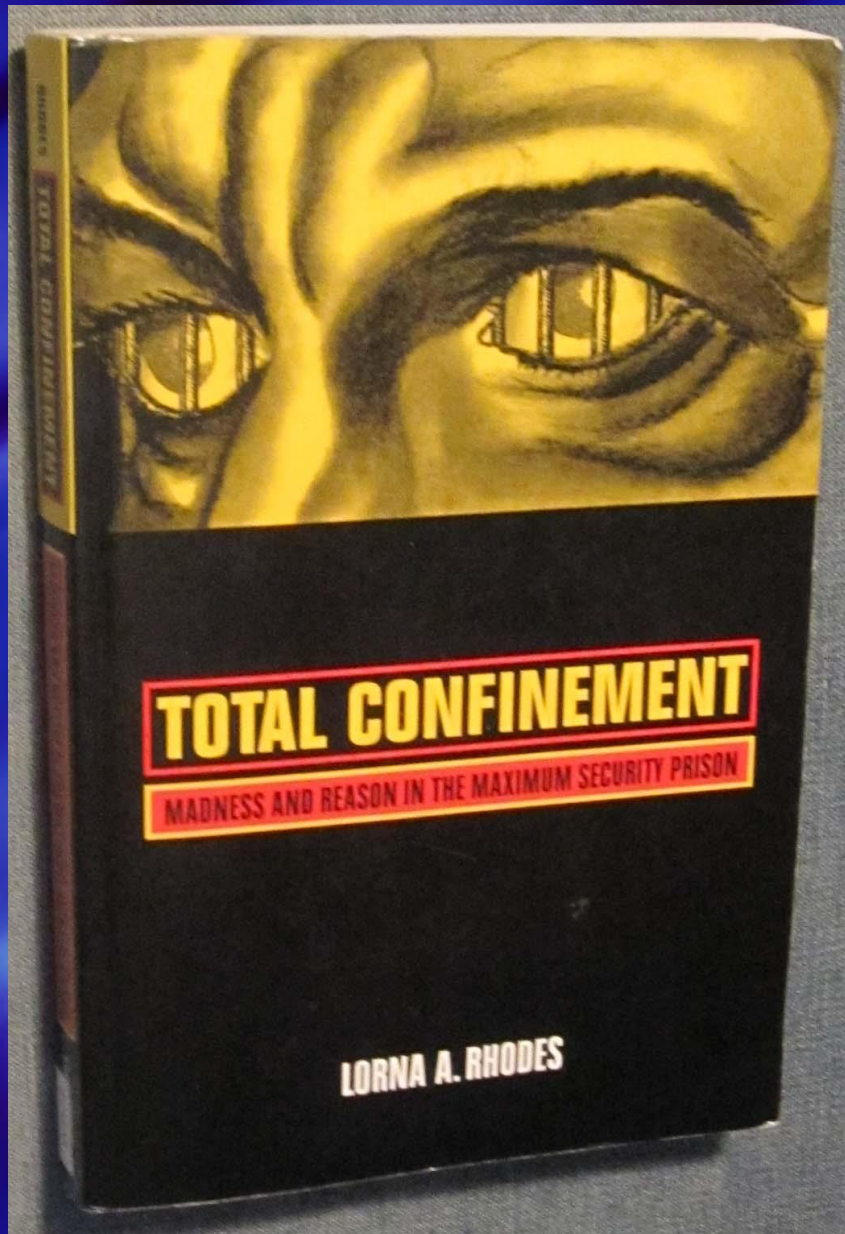

Anthropologist  
Lorna Rhodes had  
free access to the  
Washington State  
supermax for ten  
years.



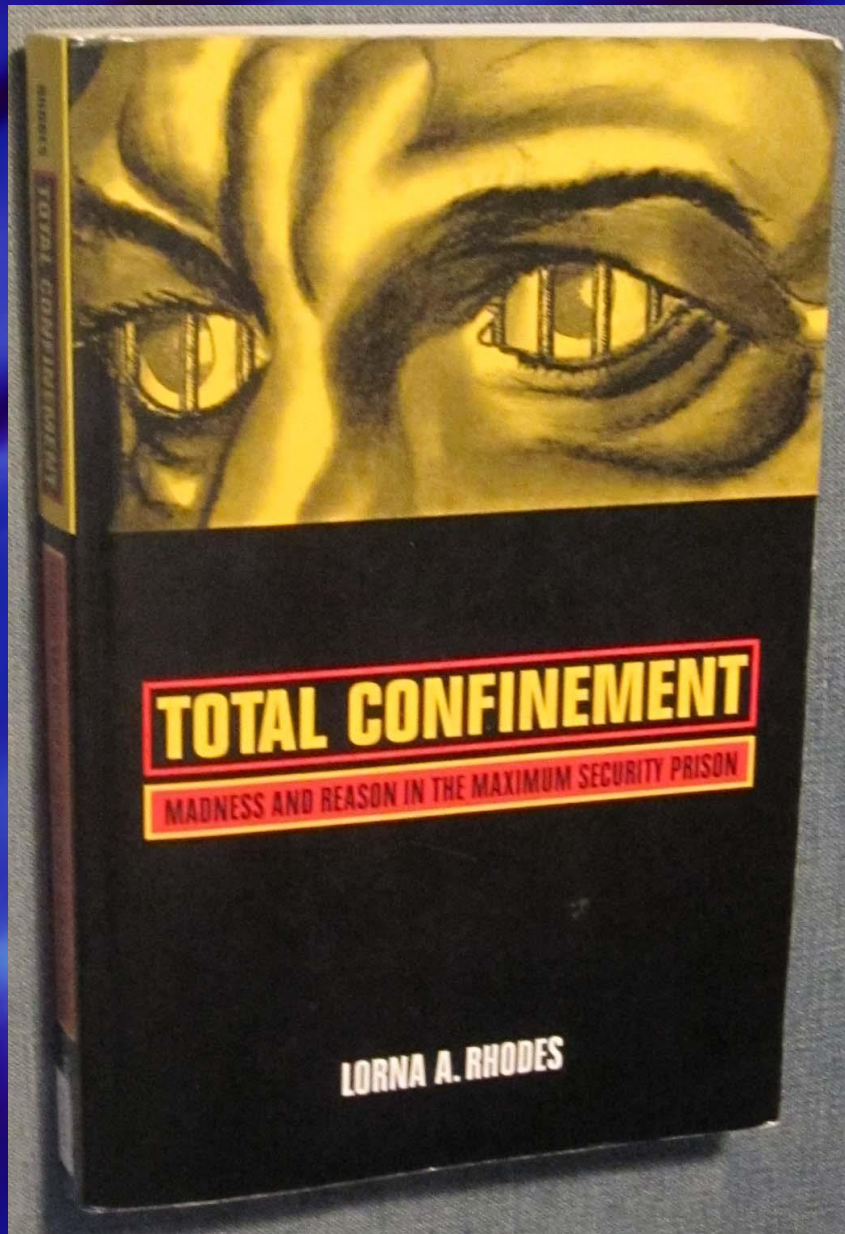

“A truly remarkable book. The inside look at supermax confinement alone is worth the price of admission. This is meticulous scholarship.”

– Hans Toch, criminologist

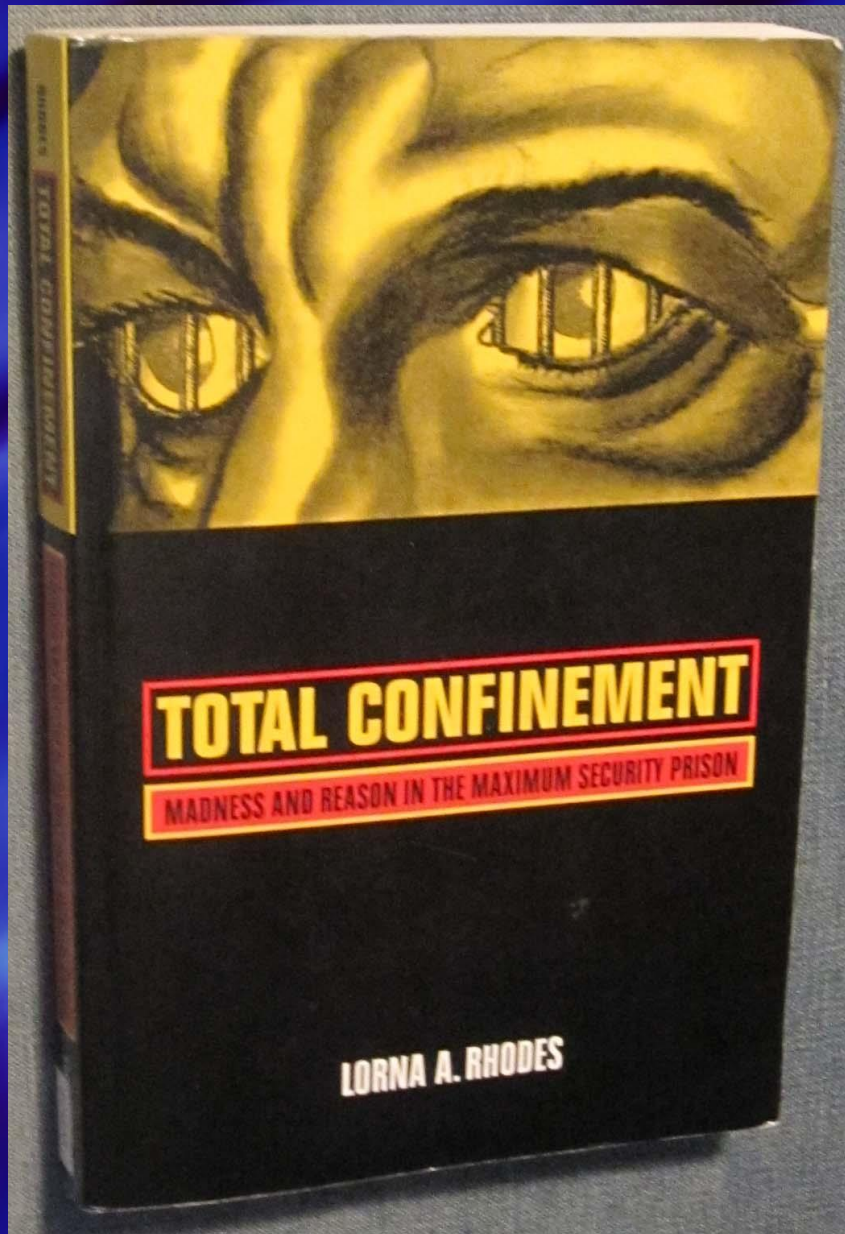

As a result of this book Washington State is considering changes to its whole prison system.

Rhodes writes:

Solitary confinement is dehumanizing.

# Rhodes writes:

Disturbed mental states are addressed by imposing conditions that further disturb the mind.

# Rhodes writes:

One officer opens the cuffport and stands carefully to one side while the other, who is dressed in a waterproof jumpsuit, quickly pushes in the food tray. Sometimes inmates stab them through the opening or hurl feces or urine at them.

# Rhodes listened:

It builds you into a monster because it hardens your feelings. — *Inmate*

# Rhodes listened:

On the third day I started going wall to wall, banging myself. — *Inmate*

# Rhodes listened:

I'm like Cerberus at the gates of hell.

— *Psychiatrist who screens new inmates*



# Rhodes listened:

I just went off, spitting, urinating....  
If they feel like I'm gonna be a badass,  
why not? — *Inmate*

# Rhodes listened:

Isolation is the worst thing we do to people.

— *Washington State Prison Official*



- Alcatraz prison was closed in 1963  
250 inmates



- Alcatraz prison was closed in 1963  
250 inmates
- Marion Illinois supermax took its place  
500 inmates



- Alcatraz prison was closed in 1963  
250 inmates
- Marion Illinois supermax took its place  
500 inmates
- We're building more supermaxes  
50,000 inmates in solitary and growing



Alcatraz – you could talk to somebody





Supermax – you're all by yourself



# Supermax Prisons

Time Magazine, January 2007

Cell resembles nothing so much as a large, concrete closet.



# Supermax Prisons

Time Magazine, January 2007

Majority of Texas and California inmate suicides occur in solitary.

# Supermax Prisons

Time Magazine, January 2007

Prisoners' brain waves shift toward a pattern characteristic of stupor and delirium.

# Supermax Prisons

Time Magazine, January 2007

Within 48 hours the breakdown is even worse when sensory deprivation is added.

# Supermax Prisons

Time Magazine, January 2007

Demolish their psyches while they're in prison, and nobody's safer when they get out.

# Time Quotes Harvard Psychiatrist

*Stuart Grassian*

We have to ask ourselves why we're doing this.

# Time Quotes Harvard Psychiatrist

*Stuart Grassian*

These aren't a bunch of cold, controlled  
James Cagneys.

# Time Quotes Harvard Psychiatrist

*Stuart Grassian*

We're taking criminals who are already unstable and driving them crazy.

# Dr. George Hunsinger

*Professor, Princeton Theological Seminary*

Solitary traumatizes people for life.



# Torture

. . . any act by which severe pain or suffering, whether physical or mental, is intentionally inflicted on a person . . . .

– *U.N. Convention Against Torture, Article 1.1*











The jury votes:

Is solitary confinement torture?

- “Yes! Fatal to health”

– *de Tocqueville*

The jury votes:

Is solitary confinement torture?

- “Yes! Shatters the mind”
  - *U.S. Supreme Court*



The jury votes:

Is solitary confinement torture?

- “Yes! It is a gulag.”

– *Hans Toch*

The jury votes:

Is solitary confinement torture?

- “Yes! Dehumanizing.”

– *Lorna Rhodes*

The jury votes:

Is solitary confinement torture?

- “Yes! We’re driving them crazy.”

– *Stuart Grassian*

The jury votes:

Is solitary confinement torture?

- “Yes! Kids become zombies.”

– *Father Joseph Romano*

The jury votes:

Is solitary confinement torture?

- “Yes! Some howl in constant agony.”

– *Lance Tapley*

The jury votes:

Is solitary confinement torture?

- “Yes! It disrupts personality.”

– *U.S. Senate*

The jury votes:

Is solitary confinement torture?

- The foreman asks us.

How do you vote?



Is solitary  
confinement  
torture?

# If it is . . . .

- Write President Obama that we should not torture prisoners in American prisons.

# If it is . . . .

- Write the National Institute of Corrections to prohibit torture in corrections.

# If it is . . .

- Ask the governor to close the state supermax.

# If it is . . .

- Send a copy of your letter to the newspapers.

# If it is . . . .

- Schedule a program on prisons for your library,  
school,  
church,  
whatever.

# If it is . . .

- Ask our state & federal representatives not to spend our taxes on supermax torture.
- Send a copy to the newspapers.

If it is . . . .

Decide how  
you'll. . . .



Speak  
your  
mind.









